

This paper reports a study aimed at assessing fire resistance of reinforced concrete ribbed slabs at the onset of integrity loss limit state. EN 1992-1-2 lacks calculation methodology for determining the limit of fire resistance of reinforced concrete slabs when the limit state of integrity loss occurs. Scientific works are focused on two limit states of fire resistance: load-bearing capacity and heat-insulating capacity. Experimental tests are criticized because of difficulties in registering signs of the onset of the limit state of loss of integrity, in particular due to the need to control the unheated surface of the ribbed plate during a fire under the action of mechanical load. Therefore, there is no calculation methodology for assessing the fire resistance of reinforced concrete ribbed slabs upon the onset of the limit state of loss of integrity. At the same time, to ensure the safe evacuation of people in the event of a fire, to prevent the spread of fire, as well as to carry out the effective work of rescuers, it is necessary to use building structures with guaranteed fire resistance classes.

The paper reports the results of solving thermal engineering and static problems, which relate to the temperature distribution and stress-strain state of the investigated ribbed plate. Conducting research into the fire resistance of reinforced concrete ribbed slabs, taking into account the onset of the limit state of loss of integrity, made it possible to establish the dependence of the fire resistance limit of these structures on the loss of integrity on the level of applied mechanical load. The resulting dependence plot makes it possible to evaluate reinforced concrete ribbed slabs according to the criterion of the onset of the limit state of loss of integrity, which provides an opportunity to determine fire resistance more objectively

Keywords: fire resistance of reinforced concrete ribbed slabs, fire modeling, through cracks, loss of integrity

DEFINING A PATTERN IN THE LOSS OF INTEGRITY BY RIBBED PLATES UNDER FIRE CONDITIONS

Stanislav Sidnei

Corresponding author

PhD, Associate Professor

Department of Safety of Construction and Occupational Safety*

E-mail: sidney-1980@ukr.net

Serhii Gonchar

Department of Fire Prevention Work*

Maxim Zhuravskij

PhD, Associate Professor

Department of Educational Activity Organization

of the Educational and Methodological Centre**

Ihor Matsyk

PhD Student***

Ihor Nozhko

PhD

Department of Fire Prevention Work*

Olena Petukhova

PhD, Associate Professor

Department of Fire Prevention in Settlements**

Taras Shnal

Doctor of Technical Sciences, Professor***

Viktor Vykhrystenko

Department of Internal Quality Assurance of Education

of the Educational and Methodological Center*

*Cherkasy Institute of Fire Safety named after Chernobyl Heroes

of the National University of Civil Defence of Ukraine

Onoprienka str., 8, Cherkasy, Ukraine, 18034

**National University of Civil Defence of Ukraine

Chernyshevska str., 94, Kharkiv, Ukraine, 61023

***Department of Building Constructions and Bridges

Lviv Polytechnic National University

S. Bandery str., 12, Lviv, Ukraine, 79013

Received date 09.08.2024

Accepted date 17.10.2024

Published date 30.10.2024

How to Cite: Sidnei, S., Gonchar, S., Zhuravskij, M., Matsyk, I., Nozhko, I., Petukhova, O., Shnal, T., Vykhrystenko, V. (2024).

Defining a pattern in the loss of integrity by ribbed plates under fire conditions. Eastern-European Journal of

Enterprise Technologies, 5 (7 (131)), 15–24. <https://doi.org/10.15587/1729-4061.2024.313935>

1. Introduction

Modern construction is aimed at minimizing costs but, at the same time, it is necessary to ensure the strength of building structures, which is a prerequisite for safety and comfort for people in buildings and at facilities [1]. Savings of funds are expected due to the reduction of material costs in the manufacture of structures, which reduces their weight. As a result, economic expediency is achieved when arranging

the foundation. One of the types of such building structures is reinforced concrete ribbed slabs, which have less weight compared to solid slabs of the same thickness, which reduces the load on the foundation (Structville). This makes it possible to save on materials for both slabs and foundations. Due to the reduction of the volume of concrete and steel required for the production of ribbed slabs, the total cost of materials is reduced. The construction of ribbed plates provides high strength and rigidity at a lower weight, which makes it pos-

sible to maintain the necessary technical characteristics of buildings. Ribbed plates are lighter and more convenient for transportation and installation, which reduces construction costs. Reducing the weight of structures leads to lower costs for the foundation, which is an important component in construction. Thus, the use of ribbed slabs makes it possible to achieve significant cost savings without harming the safety and comfort of operation of buildings and structures. The use of such structures, in comparison with flat slabs or a monolithic floor, reduces the natural weight of the floor by up to 40 %, reduces the consumption of concrete by up to 60 % due to removal from the lower stretched zone. At the same time, the rigidity of ribbed slabs is not inferior to monolithic and flat floors. This makes it possible to arrange long spans without using additional supports up to 18 meters, which makes it possible to provide more space for the installation of industrial facilities. Thus, ribbed slabs are an expedient and effective solution in modern construction due to their cost-effectiveness, reduced weight of structures, improved stability, and the possibility of covering large spans. This makes it possible to design more functional and aesthetically attractive buildings with increased comfort for users.

Therefore, research into the behavior of reinforced concrete ribbed slabs under the influence of a standard fire temperature regime, as well as mechanical load, is relevant. Given that ribbed slabs provide economy, reduce the weight of structures, and allow covering large spans without additional supports, understanding their fire resistance is key to ensuring the safety and reliability of modern buildings. This will enable building stable and durable structures that meet the requirements of construction and operation, with minimal costs.

2. Literature review and problem statement

In order to prevent the spread of fire inside a building, at the design stage it is necessary to use building structures with the appropriate class or limit of fire resistance. This will help prevent the spread of dangerous fire factors over the specified time. EN 1992-1-2 describes a general refined calculation method for evaluating the fire resistance of reinforced concrete floor slabs. It is used only to establish the time of onset of the loss of bearing capacity (R) and thermal insulation capacity (I) [2, 3].

In this case, the calculations are carried out according to the simplified (zone) method and for slabs with a cross-section of only 200 mm.

In other words, using the given temperature curves in EN 1992-1-2 for evaluating ribbed plates by this method is not considered possible at all [4]. In addition, the zone method provides for checking the fire resistance only upon the onset of the limit state of loss of bearing capacity. This approach is not objective and does not make it possible to determine the limit or class of fire resistance of reinforced concrete slabs upon the onset of the limit state of loss of integrity [4]. That is, there are no methods for determining the limit of fire resistance by the onset of the limit state of loss of integrity E in reinforced concrete floor slabs and coverings in EN 1992-1-2 [5]. It should be noted that the tabular test method for floor slabs and coverings [6] imposes too strict requirements on these structures. This method does not take into account the materials from which the structures are made, the geometric characteristics of the section, in partic-

ular the moment of resistance, and also does not take into account the load level. This significantly complicates the use of ribbed slabs in construction.

In addition, this method has cross-sectional limitations [6], which makes it ineffective for evaluating the fire resistance of ribbed slabs. These restrictions relate to the fact that for the application of the tabular method, the minimum width of the rib and the thickness of the plate itself must be at least 80 mm. This means that structures with smaller dimensions cannot be rated for fire resistance using this method. Many scientific works tackle this determination of fire resistance of reinforced concrete floor slabs, but they also report studies of only the occurrence of two limit states of fire resistance, bearing capacity R [7, 8], and thermal insulation capacity I [9, 10].

Determination of the bearing capacity of reinforced concrete slabs under the influence of high temperatures is considered in [7]. The author emphasizes the reduction of mechanical characteristics of reinforcement and concrete under fire conditions. A critical aspect of the study is that it does not include the effect of cracking, which may lead to an underestimation of the durability of the structure. Also, in [8], research is focused on the verification of calculation methods, including with the help of various software packages, exclusively on the loss of bearing capacity, without taking into account other factors, such as, for example, thermal insulation capacity or structural integrity. In [9], the ability of reinforced concrete slabs to provide thermal insulation during a fire, i.e., limit state I , is studied. Although the work is useful for evaluating the behavior of materials at elevated temperatures, it does not take into account the interaction between mechanical and thermal loads. This is an important aspect because significant temperature fluctuations can lead to cracks that weaken the thermal insulation of the slab. Also, in the work, insufficient attention is paid to the analysis of dynamics in crack propagation and the impact of these processes on the overall fire resistance. In [10], the temperature distribution over the slab under the influence of the standard fire temperature regime is also analyzed to assess the fire resistance of such structures. In this case, the study does not cover the appearance of through cracks. This state of affairs is caused by the limitations of theoretical ideas about the mechanisms and phenomenology of concrete deformation under the conditions of thermally forced impact during a fire [11]. This limitation is especially evident when trying to predict through defects in reinforced concrete enclosing structures, which are associated with registering the onset of the limit state of loss of integrity as a result of the thermal effect of a fire. The phenomenon of destruction is a complex process that begins long before the appearance of visible cracks. Given the lack of a unified theory of the destruction process, the regularities of this process are being investigated in order to better understand how damage accumulates and develops to a critical stage, when the building structure loses its integrity. In work [4], a study of the effect of mechanical load on the fire resistance limit of a ribbed plate was carried out but, in the work, only the onset of the loss of bearing capacity was taken into account. According to the results of calculations in [4], it was established that the limit of fire resistance when the structure is loaded at 50 % of the load-bearing capacity is 43.9 min, which does not make it possible to ensure the fire resistance class even REI 45. But at the same time, the limit state of loss of integrity for this structure in work [4] was not carried out, which

makes it impossible to confirm compliance with the fire resistance limit of 43 min, relying only on the load-bearing capacity of the slab.

In addition, when performing calculations for studies of loss of integrity under the influence of fire and mechanical loading, it is necessary to take into account which theory of strength is adopted for concrete. In [12], it was shown that during simulation, it was not possible to achieve the formation of through cracks in a hollow plate due to the stop of calculations in the presence of a large number of finite elements that have reached plastic deformation. The difference of work [13] was the application of the William-Warnke strength theory, which made it possible to simulate the formation of through cracks during thermally forced impact on the structure. Therefore, it can be assumed that the Drucker-Prager strength theory, used in studies [4], will not make it possible to obtain the limit state of loss of integrity.

According to EN 1363-1:2020 and EN 1365-2:2014, it is still possible to evaluate the fire resistance of building structures using experimental studies [14]. Experimental studies include full-scale fire tests, which involve replicating a building on a full scale and creating the thermal effects of a fire on these structures. This method is much more expensive than all existing ones and is difficult to implement since reproducing the thermal effect according to the curve of the standard temperature regime in a certain room of the building is not an easy task. This requires additional research to determine the number of burners, smoke vents, their configuration and location [14, 15]. Experimental tests involve conducting studies on fire resistance assessment of a separate building structure or its fragment [14, 15]. This method is less time-consuming and expensive but the manufacture of building structures and their transportation to the place of research is also a difficult task. This is due to the fact that the number of specialized laboratories that have the right to carry out such work is limited. However, this approach is subject to justified criticism from the point of view of the possibility to record signs of the onset of the limit state of loss of integrity. In particular: causing ignition of a cotton swab brought to an unheated surface of the structure; ensuring the possibility of penetration of a probe of appropriate sizes into the cracks formed; or the occurrence of persistent flame burning also from the unheated surface of the structure.

Therefore, it is necessary to constantly monitor the unheated surface of the reinforced concrete ribbed slab during tests [13, 14]. The practical experience of these tests shows that such control is impossible since the unheated surface of reinforced concrete floor slabs is covered with loads to reproduce the conditions of mechanical loading during the operation of a real structure [16, 17].

A similar situation is observed in [16, 17], in which tests are described with the use of parametric effects of fire on premises in which the use of floor slabs is expected. Determination of the limit of fire resistance of plates was carried out upon the onset of the loss of bearing capacity, i.e., upon acquisition of a critical deflection without taking into account the formed cracks.

This state of affairs does not make it possible to determine the limit of fire resistance of reinforced concrete slabs based on the limit state of loss of integrity, which calls into question the objectivity of the results. Therefore, determining the regularity of the limit of fire resistance upon the onset of the limit state of loss of integrity in ribbed slabs de-

pending on the level of the applied load will make it possible to more objectively assess such building structures.

3. The aim and objectives of the study

The purpose of our work is to determine the regularities of the onset of the limit state of loss of integrity in ribbed plates under the influence of the applied mechanical load. This will make it possible to increase the reliability of such structures during a fire, due to taking into account the obtained fire resistance indicators related to the formation of cracks through which the penetration of dangerous fire factors is possible.

To achieve the goal, the following tasks were set:

- to conduct a computer simulation of the effect of a standard fire temperature regime on a reinforced concrete ribbed slab in the ANSYS APDL software package within 60 minutes;
- to determine the stress-strain state of a reinforced concrete ribbed slab during fire exposure using computer simulation;
- based on the results of the thermally forced calculation, determine the dependence of the loss of integrity of the reinforced concrete ribbed slab on the level of the applied mechanical load.

4. The study materials and methods

The object of our study is the fire resistance of reinforced concrete ribbed slabs when the limit state of integrity loss occurs.

The hypothesis of the study assumes that the limit of fire resistance of reinforced concrete ribbed slabs at the onset of loss of integrity depends on the level of load.

To study the conditions of occurrence of the limit state of loss of integrity of reinforced concrete ribbed slabs, a separate reinforced concrete ribbed slab [4], the structural scheme of which is shown in Fig. 1, was considered. This slab is a typical reinforced concrete product according to the project documentation containing series 1.465.1. This series contains basic design data for ribbed reinforced concrete slabs covering single-story production and warehouse buildings. The main features of this plate are the presence of ribs with reinforcing rods to strengthen the panel between its ribs.

To conduct computational experiments, first to solve the thermal engineering problem of the ribbed plate model, and then to resolve the combined thermal and mechanical influence, the following basic provisions were adopted when constructing a finite element model:

1. An 8-node hexahedral finite element was accepted for modeling concrete and absolutely solid supports, and a 2-node rod finite element for modeling steel reinforcement.
2. All types of finite elements are physically nonlinear; their properties correspond to models of nonlinear behavior of materials.

The dimensions and number of finite elements in the scheme of a reinforced concrete ribbed slab are given in Table 1.

The parameters that determine the mesh density are chosen to enable good convergence of the computational process.

Fig. 2 shows the general view of the finite-element diagram of a reinforced concrete ribbed slab, which is a correspondingly discretized calculation area.

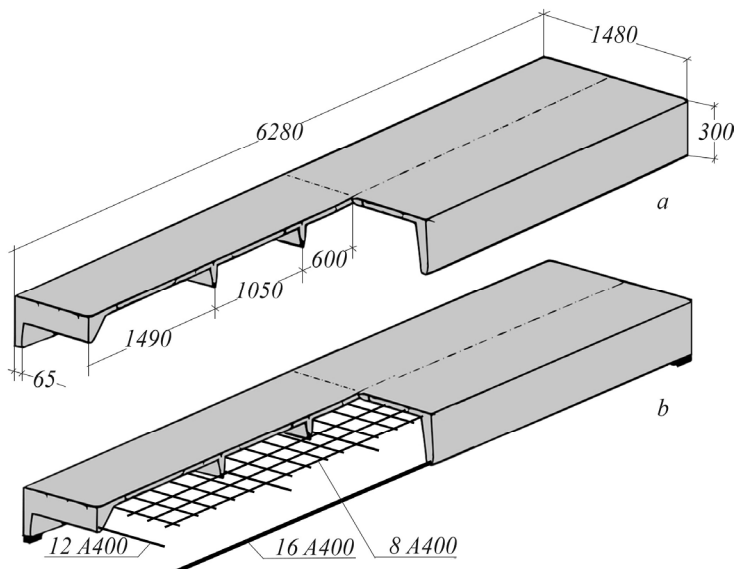

Fig. 1. The researched reinforced concrete ribbed slab [4]: a – general view; b – structural diagram

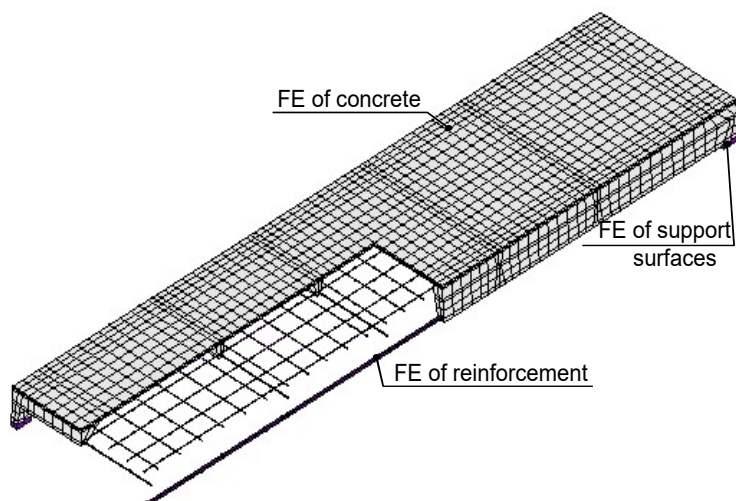

Fig. 2. Finite-element diagram of a reinforced concrete ribbed slab with support surfaces

Table 1
Parameters of finite element models of test samples

Part of the model	Min. size, mm	Max. size, mm	Quantity
Concrete base	25	100	4,128
Reinforcement	100	100	1,328
Supports	32.5	100	32
Total finite elements:			5,488

At the first stage, when modeling the thermal effect in the form of a temperature load on a reinforced concrete ribbed slab, a thermal engineering problem was solved. To this end, the quasi-linear non-stationary differential equation of thermal conductivity (1) is used. It is formulated with the statement of a boundary value problem, using boundary conditions of the III kind. Radiant and convective heat exchange between heating surfaces and the environment in a room with a fire is taken into account:

$$c_p(\theta)\rho(\theta)\frac{\partial\theta}{\partial t} = \nabla(\lambda(\theta)\nabla\theta), \tag{1}$$

where $\rho(\theta)$, $\lambda(\theta)$, $c_p(\theta)$ are the heating temperature-dependent density of concrete, coefficient of thermal conductivity of concrete, and specific heat capacity of concrete, respectively.

The temperature regime of influence on a reinforced concrete ribbed slab is calculated according to the standard fire temperature regime EN 1363-1:2020, which is determined from the following dependence:

$$\Theta_s = 345 \lg(8t + 1) + 20, \tag{2}$$

where t is the time counted from the start of the test, min; Θ_s is the temperature corresponding to time t , °C.

The thermophysical characteristics of concrete and reinforcement correspond to the temperature dependences recommended by EN 1992-1-2.

The parameters of the boundary conditions of the thermal effect on the reinforced concrete ribbed slab are given in Table 2.

Technical data of concrete are given in Table 3. Table 3 shows the main characteristics for the concrete of the reinforced concrete ribbed slab, which was used during the simulation.

Technical data on reinforcing steel are given in Table 4. This table shows the main characteristics for steel reinforcing bars of reinforced concrete ribbed slab.

To obtain reliable results regarding the behavior of a reinforced concrete ribbed slab under conditions of thermal influence and mechanical load, the corresponding deformation characteristics of concrete and reinforcement are applied. Simulation was carried out in the ANSYS APDL software package using the “strain-stress” diagram. These characteristics are recommended by EN 1992-1-1 and EN 1992-1-2 and are shown in Fig. 3.

Fig. 4 shows a diagram of a ribbed plate with a distributed load applied to its upper surface.

Table 2

Parameters of boundary conditions for a reinforced concrete slab

Parameter	Designation	Measurement unit	Value	Reference
Heated side				
Convective component of the heat exchange coefficient	α_c	W/(m ² °C)	25	EN 1991-1-2 Eurocode 1
Degree of blackness	ε	–	0.7	EN 1992-1-2 Eurocode 2
Unheated side				
Heat transfer coefficient	α	W/(m ² °C)	9	EN 1991-1-2 Eurocode 2

Table 3

Technical data on reinforced concrete ribbed slab

Parameter	Measurement unit	Value
Strength class of concrete	MPa	C 25/20
Density	kg/m ³	2400
Strength limit	MPa	20
The size of the coarse aggregate	m	0.02
Poisson’s ratio	–	0.3

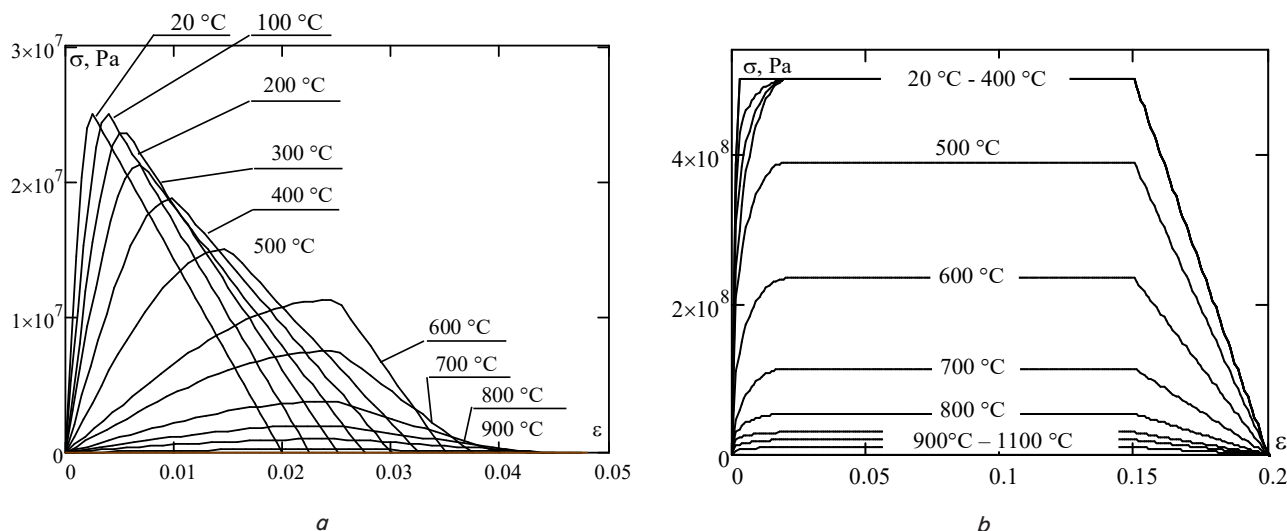

Fig. 3. Diagrams of material deformation, which are components of reinforced concrete hollow slab: *a* – concrete; *b* – reinforcing steel

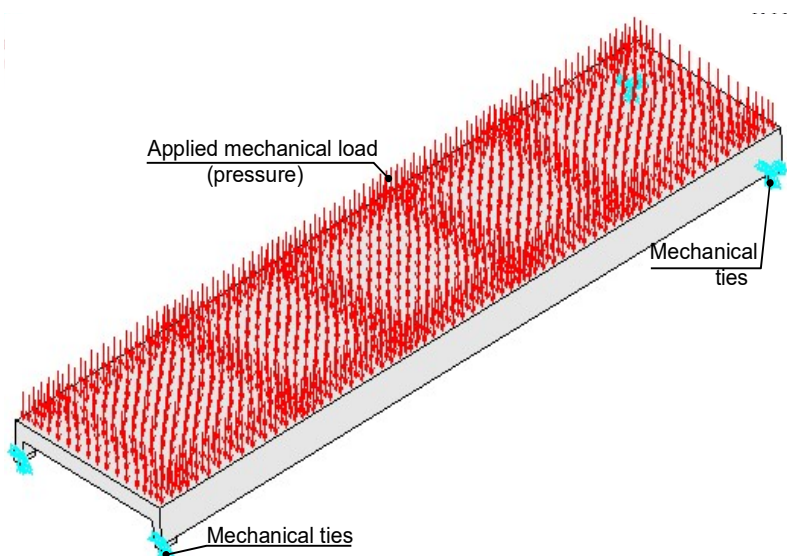

Fig. 4. The scheme of applying a mechanical load to the surface of a reinforced concrete ribbed plate at different load levels depending on the bearing capacity: 30 % – 1.8 kN/m², 50 % – 3 kN/m², 70 % – 4.2 kN/m², 90 % – 5.4 kN/m²

Table 4

Technical data on the reinforcing steel of the ribbed plate

Parameter	Measurement unit	Value
Density	kg/m ³	7850
Modulus of elasticity	MPa	2·10 ⁵
Poisson's ratio	–	0.2
Reinforcement in longitudinal ribs		
Strength class	MPa	A400
Strength limit	MPa	400
Diameter	mm	16
Reinforcement in transverse ribs		
Strength class	MPa	A400
Strength limit	MPa	400
Diameter	mm	12
Panel reinforcement		
Strength class	MPa	A400
Strength limit	MPa	400
Diameter	mm	8

Fig. 4 shows on the given diagram of a reinforced concrete ribbed plate the supporting surfaces, which are solid bodies, which is determined by the adopted material. Resting the plate on these supports is carried out by simulating the contact interaction between individual parts of the model, automatically created in the system as parts of different materials. The contact interaction is established as an automatic “surface-surface” type, taking into account the friction between them according to the generalized Coulomb's law with the coefficient of friction $\mu=0.6$ (friction between the steel surface and the concrete surface).

According to the recommendations (IntechOpen-Open Science Open Minds), the static problems of modeling the stress-strain state of reinforced concrete slabs when they are unilaterally affected by a fire with a standard temperature regime were solved with a step-by-step reproduction of the load history in two stages. At the first stage, the heat load was simulated in the form of the influence of the standard fire temperature regime. However, the impact of

the fire on the reinforced concrete ribbed slab occurred after the structure accepted the mechanical load in the form of a uniformly distributed load. At the second stage, a static problem was already solved, which involves a compatible thermally forced effect on a reinforced concrete ribbed slab.

The mathematical models used to calculate the behavior of a reinforced concrete ribbed slab under conditions of combined thermally forced influence are based on the application of the implicit method for integrating differential equations of the stress-strain state using the finite element method.

5. Results of determining the regularity of limit of fire resistance of ribbed plates according to the loss of integrity because of load

5.1. Results of solving the heat engineering problem

When modeling the process of heat transfer in a reinforced concrete ribbed slab under the thermal influence of the stan-

standard fire temperature regime, temperature data in the inner layers were obtained. Fig. 5 shows temperature distributions in a reinforced concrete ribbed slab at different times.

Fig. 5 demonstrates that the inner layers of the plate heat up quite strongly, especially in the panel between the ribs.

To analyze the heating of reinforcing bars, the temperature curves of their heating depending on time were constructed. Fig. 6 shows the constructed heating curves of reinforcement in a reinforced concrete ribbed slab.

In order to analyze the onset of the limit state of loss of thermal insulation capacity, a plot of average temperature on the unheated surface of the studied reinforced concrete slab was constructed. Fig. 7 shows the constructed temperature plot of heating the non-heated surface of the plate, which also demonstrates the limit temperature for the onset of the state of loss of heat-insulating capacity.

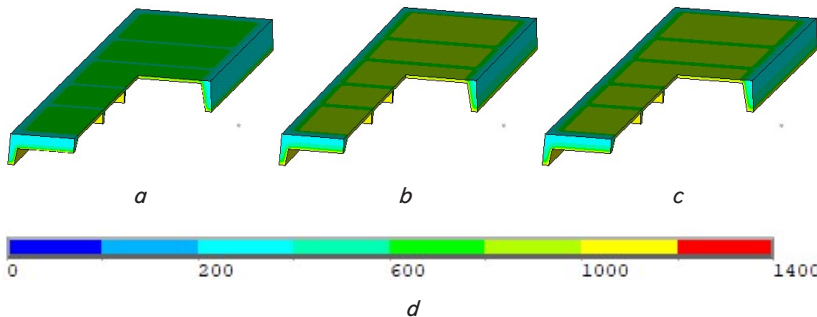

Fig. 5. Temperature distributions in a reinforced concrete ribbed slab at different moments of exposure to the standard fire temperature regime (2): a – 30 min; b – 45 minutes; c – 60 minutes; d – temperature distribution gradient across the plate

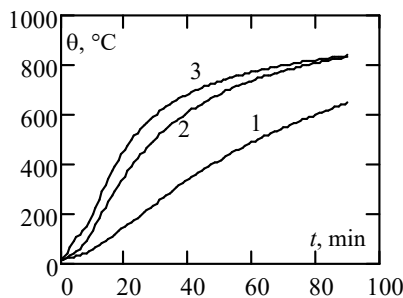

Fig. 6. Temperature curves of heating the reinforcing bars in a reinforced concrete ribbed slab depending on time: 1 – in the longitudinal rib; 2 – in the transverse rib; 3 – in the panel between the ribs

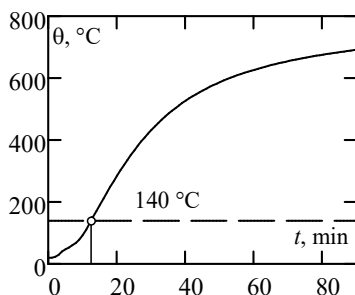

Fig. 7. Heating plot of the unheated side of the investigated reinforced concrete ribbed slab

According to EN 1363-1:2020, the criterion for the occurrence of the limit state of the loss of thermal insulation capacity is an excess of the average temperature on the unheated surface

of the slab by 140 °C or an excess at any point by 180 °C. Thus, the plot in Fig. 7 shows that the limit of fire resistance upon onset of the state of loss of heat-insulating ability for this plate is 13 minutes. This is permissible for covering plates since the loss of heat-insulating capacity is not standardized for them.

5. 2. Results of determining the stress-strain state of a reinforced concrete ribbed slab during fire exposure

Our results from solving the heat engineering problem, which are described above, were used to calculate the parameters of the stress-strain state of the reinforced concrete ribbed slab according to the adopted approach. After the calculations, a set of data on the stress-strain state was built, which should be analyzed to identify aspects and regularities of the onset of the limit state of loss of integrity of a reinforced concrete ribbed slab under the thermal influence of a fire. Thus, Fig. 8 shows the distribution of vertical displacements (m) in the studied reinforced concrete ribbed slab at different time points of exposure to the standard fire temperature regime at a load level of 50 % of the bearing capacity.

Also, one of the calculated parameters, which is important for evaluating the possibility of the formation of through defects in reinforced concrete ribbed slabs, is the stress at which plastic deformations occur in concrete. This parameter helps determine the onset of the limit state of loss of integrity,

Fig. 9 shows constructed distributions of stress values at which plastic deformations occur at different time points at a load level of 50 % of the bearing capacity.

Another important parameter that makes it possible to record the onset of the limit state of loss of integrity is the distribution of “cracks”, the onset of which is identified at the integration points (Fig. 10). Fig. 10 shows the obtained distribution of cracks at different time points. Conventional designations of cracks in concrete (Fig. 11) include: primary cracks – in red, which are the first cracks that appear in the element. Secondary cracks are in green, representing the first branching of primary cracks, and tertiary cracks are in blue, which form the second branching in the structure of the element.

The signs of cracks and defects in concrete are decoded in Fig. 11.

To understand the mechanism of destruction of the inner layers of the slab, vertical displacement curves of the reinforced concrete ribbed slab were constructed for different load conditions. Fig. 12 shows the plotted curves.

According to the results of solving the static problem, it was established that nonlinear deformations in the cell between the ribs of the ribbed plate occur on minute 17, 18, 22, and 25, respectively, depending on the level of mechanical load.

Fig. 13 shows the given curves, which illustrate the conditions for the onset of the limit state of loss of integrity and the method for identifying the limit of fire resistance based on these curves.

The plot in Fig. 13 demonstrates that for curve 4, the onset of nonlinear deformation occurs approximately between minutes 17 and 18, when the deflection begins to increase sharply. Dropping the normal from this point to the time axis shows that the fire resistance limit for this case will be at this time interval. The same principle is used to determine other load levels corresponding to curves 1, 2, 3.

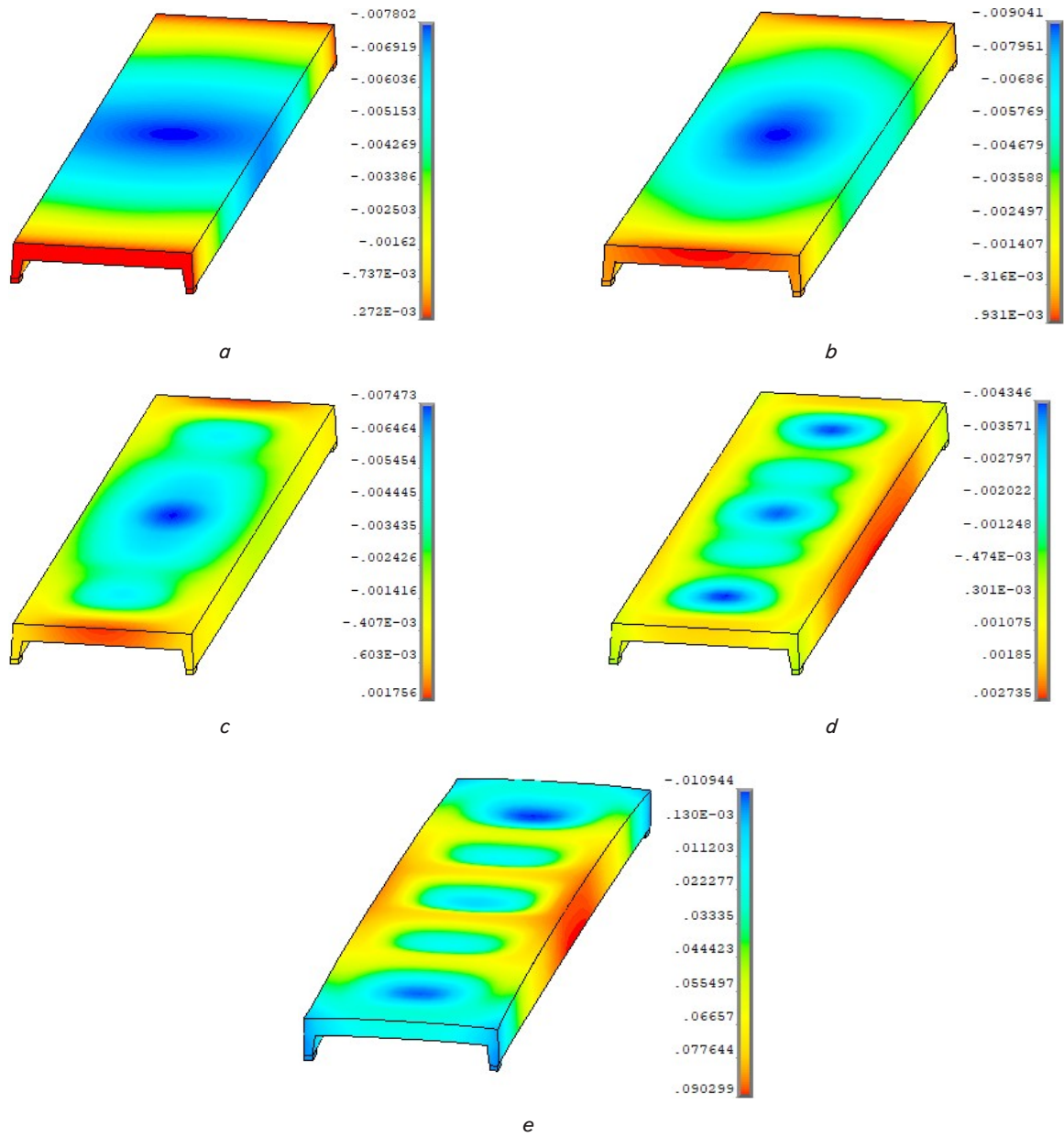

Fig. 8. Distribution of vertical displacements (m) in the investigated reinforced concrete ribbed slab at different moments of exposure to the standard fire temperature regime: *a* – 0 min; *b* – 1 min; *c* – 3 min; *d* – 5 min; *e* – 25 min at a load level of 50 % of the bearing capacity

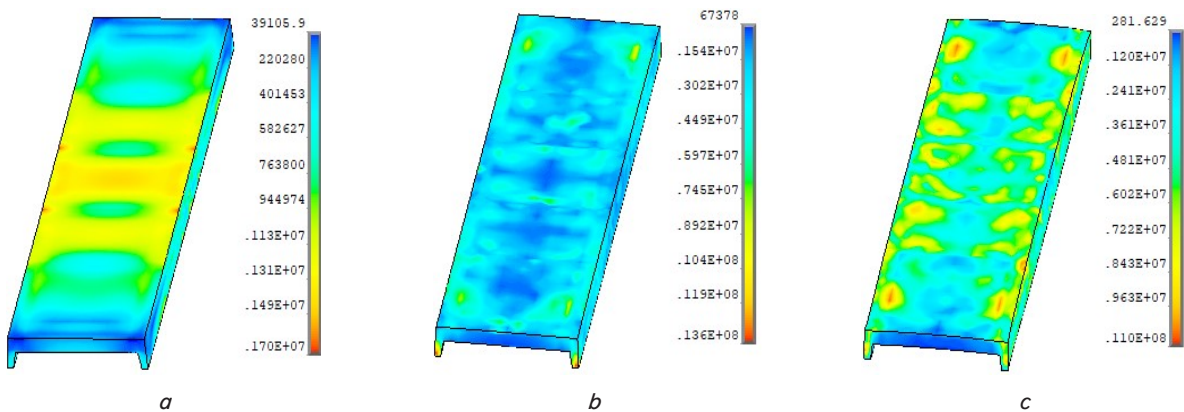

Fig. 9. Distributions of stress values (Pa) at the occurrence of equivalent plastic deformation in the space of the concrete base of the reinforced concrete ribbed slab at different moments of exposure to the standard fire temperature regime: *a* – 0 min; *b* – 10 minutes; *c* – 25 min at a load level of 50 % of the bearing capacity

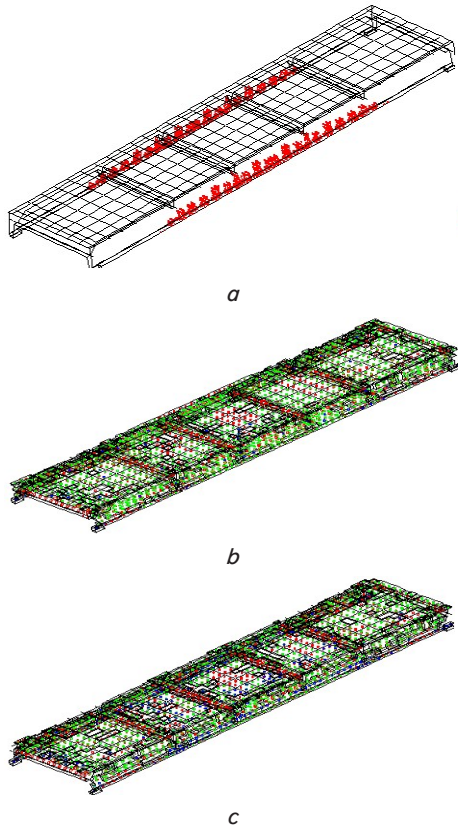

Fig. 10. Distribution of cracks in the concrete of a reinforced concrete ribbed slab at different moments of exposure to the standard fire temperature regime: a – 0 min; b – 10 minutes; c – 25 min

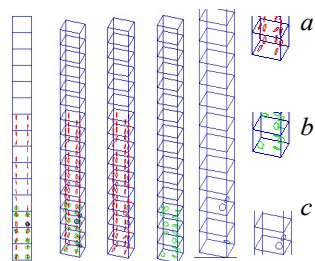

Fig. 11. Conditional designations of cracks in concrete: a – primary cracks (the first cracks that appear in the element); b – secondary cracks (the first branching of cracks that appear in the element); c – tertiary cracks (the second branching of cracks that appear in the element)

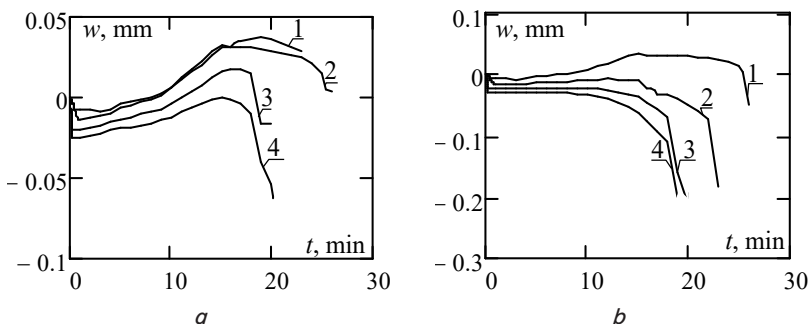

Fig. 12. Plots of the maximum deflection of a reinforced concrete ribbed slab under the influence of the standard fire temperature regime for different values of the effective load: 1 – 30 %, 2 – 50 %, 3 – 70 %, 4 – 90 % of the maximum load; a – longitudinal rib; b – points in the middle of the panel in the cell between the ribs

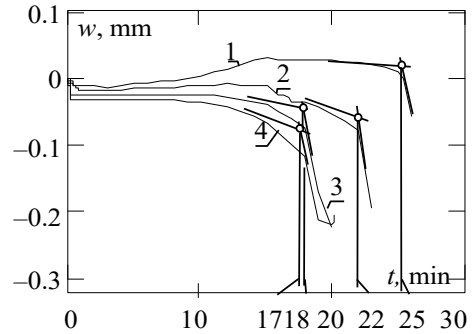

Fig. 13. Plots of the maximum deflection of the point inside the panel in the cell between the ribs of the reinforced concrete ribbed slab under the influence of the standard fire temperature regime at different values of the effective load with the established limits of fire resistance: 1 – 30 % of the maximum load; 2 – 50 % of the maximum load; 3 – 70 % of the maximum load; 4 – 90 % of the maximum load

5. 3. Determining the dependence of integrity loss on the level of applied mechanical load

Summarizing the plotted curves regarding the onset of the limit state of loss of integrity, the dependence of the fire resistance limit of the slab on the level of the applied mechanical load was determined. The method for identifying the fire resistance limit showed this interdependence. The resulting dependence in the form of a corresponding curve is shown in Fig. 14.

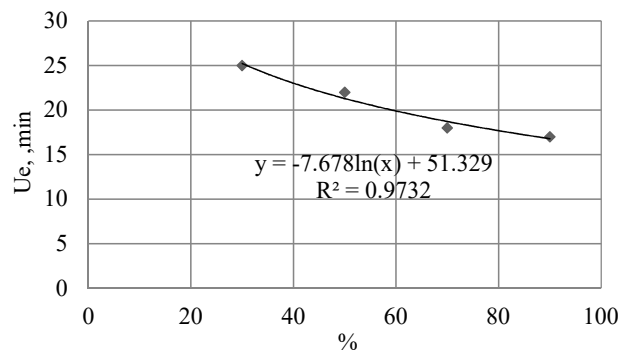

Fig. 14. The plot of dependence of the fire resistance limit of a reinforced concrete ribbed slab upon the onset of the limit state of loss of integrity on the level of the applied active mechanical load as a percentage of the maximum

Dependence on the plot in Fig. 14 shows the change in the value of the fire resistance limit U_e (in minutes) depending on the percentage of mechanical load (from 30 % to 100%), which can be described as: $U_e = -7.678 \ln(x) + 51.329$.

6. Discussion of results based on studying the assessment of fire resistance of the reinforced concrete ribbed slab depending on the loss of integrity

One can see that on the finite element diagram shown in Fig. 2, the mesh of finite elements of concrete and reinforcing frame

has a sufficiently large rarefaction. Such a mesh provides the most successful combination between performance and calculation accuracy as it is conformal with the involvement of hexahedral finite elements.

On the curves of Fig. 6, one can see that the reinforcement in the panel between the ribs heats up the most, since this reinforcement has the smallest protective layer. The temperature in the transverse ribs is a little slower, and the reinforcement in the longitudinal ribs warms up the slowest, since it has the largest protective layer.

The plot in Fig. 7 shows that the limit of fire resistance upon onset of the state of loss of heat-insulating ability for this plate is 13 minutes. This is permissible for covering plates since the loss of heat-insulating capacity is not standardized for them.

An interesting pattern of the build-up of vertical movements of the plate was obtained, which is shown in Fig. 8. One can see in Fig. 8 that under the action of the applied power load (in this case, $q_E=1.8$ kN/m, i.e., 30 % of the destructive load), the slab has the largest vertical movements in the middle of the span. In this case, the zone of the largest vertical movements has a round shape. During the simulation of the thermal effect of the standard temperature regime of the fire, initially the zone of the largest movements has the shape of an ellipse elongated along the longitudinal axis of the plate. During the stages of longer thermal exposure, the largest movements are concentrated in the slab cells formed by longitudinal and transverse ribs.

Also in Fig. 8, one can see that under the thermal influence of the fire, the ribbed plate gradually bends upwards. This can be explained by the thermal expansion of the panel between the ribs.

The given distributions show that a possible loss of integrity occurs when the panel is destroyed in the cells between the longitudinal and transverse ribs of the plate.

Analyzing the distribution of plastic stresses (Fig. 9), one can see that the hypothesis of the destruction of the concrete layer in the cells, which are formed between the longitudinal and transverse ribs of the reinforced concrete ribbed slab, is confirmed, since they are most concentrated near the ribs.

Fig. 10 shows the distribution of cracks as a result of combined thermally forced impact on a reinforced concrete ribbed slab. This distribution was obtained through the application of William–Warnke’s theory of concrete strength, as well as the use of the ANSYS APDL software package. In [4], the Drucker-Prager concrete strength theory was applied. However, this strength theory may be less accurate for modeling brittle materials subject to crack formation compared to the William–Warnke strength theory. But at the same time, the Drucker-Prager theory of concrete strength is more universal for carrying out calculations in the ANSYS WB software package [4] when conducting studies on the loss of bearing capacity.

However, analyzing the patterns of crack distributions shown in Fig. 10, it can be noted that relying only on these distributions, it is impossible to unambiguously identify the appearance of through cracks. This is due to the fact that the appearance of damage at one or more integration points does not make it possible to conclude that the cracks would be through. These cracks play the role of an effective characteristic to adequately describe the behavior of reinforced concrete during the thermal impact of fire.

Analysis of plots in Fig. 12 reveals that probably the destruction in the longitudinal edge of the plate is possible only

when the load is applied more than 70 % since a clear bend of the maximum deflection curve can be observed in this case. However, one can definitely see that the panel in the cell between the ribs has a distinct bend. This means that in all cases the destruction of the plate occurs precisely as a result of the destruction of the panel between the ribs. Therefore, it can be assumed that the limit state of loss of integrity occurs due to the destruction of the panel between the ribs (in the cells) when the bearing capacity of the longitudinal ribs is still preserved. This is logical since the protective layer of reinforced concrete in these cells is the smallest and is only 15 mm.

Considering this hypothesis, the possibility of using such an approach as a refined method for evaluating the fire resistance of reinforced concrete ribbed slabs based on the limit state of loss of integrity is assumed. According to this approach, one can use curves of the type of plots shown in Fig. 13.

The plot in Fig. 14 shows a decrease in the value of the fire resistance limit with an increase in the application of mechanical load. This dependence is linear in nature, which indicates a constant decrease in U_e with each increase in percentage. The value of the coefficient of determination $R^2=0.9732$ testifies to the high accuracy of this approximation to the data. This means that the model describes well the trend shown by the given points, with small deviations.

So, based on the results of our research, the regularity of the limit of fire resistance of reinforced concrete ribbed slabs from the level of the applied load has been determined. This makes it possible to define the fire resistance of such structures according to the constructed plot based on the limit state of fire resistance of the loss of integrity, which is a guarantee for preventing the formation of cracks through which the penetration of dangerous fire factors is possible, within the specified time.

Considering the philosophy of Eurocode 2 for assessing the fire resistance of reinforced concrete slabs, in particular with regard to loss of load-bearing capacity, it is an important approach that provides systematicity and structure. An important step would be to devise a similar hierarchical approach for reinforced concrete ribbed slabs that would take into account the specific structural and material features of these slabs. That is, the development of a hierarchical approach for evaluating the fire resistance of ribbed slabs by the onset of the limit state of loss of integrity would make it possible to more accurately predict their behavior during a fire.

A limitation of our research is that the use of a standard fire temperature regime creates more severe conditions for the structure compared to a parametric fire. This may lead to an overestimation of the fire resistance limit, but at the same time it is guaranteed to provide the required fire resistance class under any conditions.

The disadvantage of this study is the use of only one Wilm–Warnke strength theory to identify the onset of a good state of loss of integrity of a reinforced concrete ribbed slab under the conditions of thermal impact. The use of additional strength theories would make it possible to obtain more variable results, which would significantly expand the possibilities for future analysis and prediction of the behavior of structures under the influence of high temperatures and loads. It would also contribute to more accurate modeling of failure processes and could provide more sound recommendations for practical application of the results in the construction industry.

A promising area for further research is to devise a tabular method for evaluating the fire resistance of reinforced concrete ribbed slabs by the onset of the limit state of loss of integrity. This could significantly simplify the application of the method when checking compliance with the fire resistance class of such structures.

7. Conclusions

1. Based on the results of solving the thermal engineering problem, it was established that the loss of heat-insulating capacity of the ribbed plate is 13 minutes, but this is acceptable for such structures since the loss of heat-insulating capacity is not standardized for them.

2. According to the results of the solved static problem, it was established that the limit of fire resistance by loss of integrity is 17, 18, 22, 25 minutes depending on the level of mechanical load, which makes it possible to monitor the corresponding dependence.

3. Based on the results of our research, a logarithmic dependence of fire resistance limit on the loss of integrity on the level of the applied load was derived.

Conflicts of interest

The authors declare that they have no conflicts of interest in relation to the current study, including financial, personal, authorship, or any other, that could affect the study, as well as the results reported in this paper.

Funding

The study was conducted without financial support.

Data availability

All data are available, either in numerical or graphical form, in the main text of the manuscript.

Use of artificial intelligence

The authors confirm that they did not use artificial intelligence technologies when creating the current work.

References

- Hu, R., Chen, K., Jiang, W., Luo, H. (2024). IFC data extension for real-time safety monitoring of automated construction in high-rise building projects. *Automation in Construction*, 162, 105408. <https://doi.org/10.1016/j.autcon.2024.105408>
- Salihu, F., Guri, Z., Cvetkovska, M., Pllana, F. (2023). Fire Resistance Analysis of Two-Way Reinforced Concrete Slabs. *Civil Engineering Journal*, 9 (5), 1085–1104. <https://doi.org/10.28991/cej-2023-09-05-05>
- Eurocodes. Background and applications: structural fire design. Worked examples (2014). European Union. <https://doi.org/10.2788/85432>
- Sidnei, S., Berezovskyi, A., Kasiarum, S., Lytvynenko, O., Chastokolenko, I. (2023). Revealing patterns in the behavior of a reinforced concrete slab in fire based on determining its stressed and deformed state. *Eastern-European Journal of Enterprise Technologies*, 5 (7 (125)), 43–49. <https://doi.org/10.15587/1729-4061.2023.289930>
- Vasilchenko, A., Danilin, O., Lutsenko, T., Ruban, A. (2021). Features of Evaluation of Fire Resistance of Reinforced Concrete Ribbed Slab under Combined Effect “Explosion-Fire.” *Materials Science Forum*, 1038, 492–499. <https://doi.org/10.4028/www.scientific.net/msf.1038.492>
- Buchanan, A. H., Abu, A. K. (2016). *Structural Design for Fire Safety*. John Wiley & Sons. <https://doi.org/10.1002/9781118700402>
- Dzidic, S. (2023). Fire Resistance of Reinforced Concrete Slabs. *Reinforced Concrete Structures - Innovations in Materials, Design and Analysis*. <https://doi.org/10.5772/intechopen.1001046>
- Kildashti, K., Katwal, U., Tao, Z., Tam, V. (2024). Numerical simulation of steel-concrete composite beams and slabs at elevated temperatures. *Engineering Structures*, 315, 118297. <https://doi.org/10.1016/j.engstruct.2024.118297>
- Nuianzin, O., Kozak, A., Kostenko, V., Kryshal, M., Nuianzin, V., Nekora, O. (2023). The research of the fire resistance limits of a reinforced concrete slab according to the results of fire tests without mechanical load. *Strength of Materials and Theory of Structures*, 110, 264–276. <https://doi.org/10.32347/2410-2547.2023.110.264-276>
- Qin, D., Gao, P., Aslam, F., Sufian, M., Alabduljabbar, H. (2022). A comprehensive review on fire damage assessment of reinforced concrete structures. *Case Studies in Construction Materials*, 16, e00843. <https://doi.org/10.1016/j.cscm.2021.e00843>
- Sidnei, S., Nuianzin, V., Kostenko, T., Berezovskyi, A., Wąsik, W. (2023). A Method of Evaluating the Destruction of a Reinforced Concrete Hollow Core Slab for Ensuring Fire Resistance. *Journal of Engineering Sciences*, 10 (2), D1–D7. [https://doi.org/10.21272/jes.2023.10\(2\).d1](https://doi.org/10.21272/jes.2023.10(2).d1)
- Sidnei, S., Myroshnyk, O., Kovalov, A., Veselivskyi, R., Hryhorenko, K., Shnal, T., Matsyk, I. (2024). Identifying the evolution of through cracks in iron-reinforced hollow slabs under the influence of a standard fire temperature mode. *Applied Mechanics*, 4 (7 (130)), 70–77. <https://doi.org/10.15587/1729-4061.2024.310520>
- Perehin, A., Nuianzin, O., Shnal, T., Shchipets, S., Myroshnyk, O. (2023). Improvement of means for assessing fire resistance of fragments of reinforced concrete structures. *AIP Conference Proceedings*. <https://doi.org/10.1063/5.0120061>
- Kovalov, A., Otrosh, Y., Ostroverkh, O., Hrushovinchuk, O., Savchenko, O. (2018). Fire resistance evaluation of reinforced concrete floors with fire-retardant coating by calculation and experimental method. *E3S Web of Conferences*, 60, 00003. <https://doi.org/10.1051/e3sconf/20186000003>
- Li, B., Lin, Y. Q., Zhang, H. L., Ma, M. J. (2019). Fire Behavior of the Assembled Monolithic Hollow-Ribbed Slabs. *Advances in Civil Engineering*, 2019 (1). <https://doi.org/10.1155/2019/8921502>
- Zafarullah, N., Ameer, E., Nakayama, A., Muhammad Bilal, H. S. (2022). Determination of structural reliability of a reinforced concrete slab under fire Load. *E3S Web of Conferences*, 347, 01009. <https://doi.org/10.1051/e3sconf/202234701009>
- Law, A., Bisby, L. (2020). The rise and rise of fire resistance. *Fire Safety Journal*, 116, 103188. <https://doi.org/10.1016/j.firesaf.2020.103188>