



Artemev S.

INVESTIGATION OF MECHANISMS OF THE CRYSTAL GROWTH PROCESS (KOSSEL MODEL)

Об'єктом даного дослідження є механізми процесів росту кристалів. В якості моделі дослідження взято плоскогранный кристал у формі кубиків. Досліджено два механізми росту кристалів. При першому механізмі в процесі росту кристалу зростаюча поверхня рухається за рахунок бічного переміщення ступенів, при другому відбувається безперервний потік уздовж нормалі до поверхні кристала. Проблемним питанням під час вирощування кристалів зазначеними механізмами з розплаву є збереження чистоти самого металу, особливо якщо він знаходиться у розплавленому стані. Показано, що під час застосування «пошарового» механізму росту кристалів проблемним моментом є процес утворення двовимірних «зародків». Даний процес досить чутливий до пересичення, і ймовірність його проведення при показниках нижче 45–50 % досить мала. В ході досліджень були використані методи статистичного аналізу для визначення позитивних і негативних сторін використання механізмів росту кристалів, аналізу результатів досліджень для визначення динаміки використання того чи іншого механізму вирощування кристалів. Застосовувався гипотетико-дедуктивний метод в процесі ознайомлення фактичного матеріалу досліджень в області росту кристалів, які додатково вимагають поглибленого аналізу джерел інформації. Використовувався також метод узагальнення результатів для встановлення загальних властивостей і тенденцій, характерних досліджуваним механізмам росту кристалів. Обґрунтовано, що за недотримання теплових умов проведення обох процесів складно домогтися потрібної орієнтації і конфігурації кристалів. Показано, що «нормальний» механізм росту кристалів ефективний за дотримання умови того, що на поверхні має бути досить багато «енергетично вигідних» місць закріплення атомів, що не завжди може виконуватися.

Ключові слова: механізми зростання, пошаровий механізм, нормальний механізм, модель Косселя.

1. Introduction

The processes of growth of crystals until recently largely depended on the technologist, as far as he was inventive and talented.

Now science has stepped forward. Modern installations allow to obtain various crystals of a wide range. This became possible due to the fact that the processes and phenomena that occur in crystallization apparatuses during the growth of crystals, and, most importantly, on the surface of the crystal itself, began to be studied in greater depth and quality.

The science of the growth of crystals develops and at this stage continues to open new facets. After all, for example, the transistor effect and laser radiation were made on crystals – respectively, germanium and ruby. The number of publications in this area in the last 40 years has doubled on average every 10 years, which indicates the relevance of the development of this area of research. This, on the one hand, leads to the fact that some of the literature is obsolete and partly losing relevance. And on the other hand, it is in the last few years that critical series surveys have taken place, encompassing specific narrow crystallization directions, which are devoted not only to specific methods of growing crystals, but to certain classes of materials.

And this means that the aspects of this research problem do not fall out of the field of view of scientists, are relevant and worthy of further detailed study.

2. The object of research and its technological audit

The object of this research is the growth of crystals. These processes are considered using the example of the Kossel model.

The model is a plane-faced crystal in the form of cubes. Two mechanisms of crystal growth are considered.

With the first mechanism, during the growth of the crystal, the growing surface moves due to the lateral displacement of the steps (a layered mechanism); in the second, a continuous movement along the normal to the surface occurs (a normal mechanism).

A problematic issue when growing crystals with these mechanisms from the melt is the preservation of the purity of the metal itself, especially if it is in the container in the molten state for a long time.

The grown crystal must be further machined, as a result of which it deforms and loses its shape. That's why it needs to be recrystallized. However, the «recrystallization» concept is quite difficult, if to carry out this process with violations, this will lead to a change in the number, shape, size, perfection, and orientation of the crystals themselves.

A number of problematic issues will arise even if the thermal conditions of the process are not observed, super-saturation or supercooling of process parameters, disturbances in the supply of oxygen to the chamber.

When applying the layer-by-layer mechanism of crystal growth, it should be noted that the problem is the formation

of two-dimensional «embryos». This process is quite sensitive to supersaturation, and the probability of carrying out this process at rates below 45–50 % is quite small.

When using the «normal» crystal growth mechanism, the problematic issue is that it is necessary to observe the condition that there must be enough «energetically favorable» sites for fixing the atoms on the surface, which is not always feasible.

3. The aim and objectives of research

The aim of research is analysis of crystal growth processes using the Kossel model as an example.

To achieve this aim, it is necessary to solve such problems:

1. To investigate the layer-by-layer mechanism of crystal growth using the model of a plane-faced crystal as an example.

2. To investigate the normal mechanism of crystal growth on the example of the model, determine the positive and negative aspects of the process.

4. Research of existing solutions of the problem

The problems of crystal growth and methods of obtaining them are a promising direction in the study of modern science. Therefore, any source of literature is interesting enough and attractive. There are a fairly large number of methods for growing different groups of crystals, which are described in the literature.

In particular, in [1–4] the so-called container methods for growing crystals are examined in detail, methods for «stretching» crystals are investigated in [5–8]. In [9–11], the use of an electric field in crystal growth is discussed in detail, and here it should be noted both the positive aspects of the evaluation of the use of this method [12, 13] and negative ones [14].

Whole reviews are devoted to various methods and groups of growing crystals, as described in [15–19], including the use of chemical reactions [20, 21].

The growth of whiskers is widely discussed during conferences, as indicated in [22–25].

Methods for obtaining crystals are generalized in [26, 27], which is described in general in [28, 29].

The properties of crystals and their investigation are reflected in [30–34], in particular, and in [35].

A sufficient number of literary sources cover the issues of conducting practical experimental studies. In particular, in [36–39] – these are the results of studies of crystal growth from the vapor phase, and in [40–43] – using zone melting with a solvent.

The 21st century is also marked by new experiments in this direction. Theoretical and experimental studies of the formation of filamentary GaAs and AlGaAs crystals by molecular beam epitaxy are described in detail in [44]. In the present study, in order to account for the diffusion contribution to the growth of whiskers, the growth model of such crystals is considered by the above method. In this case, the proposed model takes into account both the growth of threadlike crystals by the «vapor – liquid – crystal» mechanism due to the adsorption of atoms on the droplet surface and the diffusion growth due to the fact that the atoms entered the drop from the substrate through the side surface of the crystal, which is described in detail in [45, 46].

The results of the experiment on GaAs (111) B substrates are presented in [47], on which the Au layer was previously deposited in the VUP-5 facility. Here a three-stage method for the formation of whiskers and completely described the dynamics of the experiment are considered.

The paper [48] describes the growth of whiskers on surfaces activated by a catalytic substance. In [49], features of the structure of materials based on cuprates and manganites are considered, and in [50] the differences in the morphology of the crystallites of amino acids growing on silicon substrates with a symmetrical and asymmetric surface relief are analyzed. It is shown that only in the second case a growth spiral is formed.

It was at the beginning of the 21st century that the attention of scientists was drawn to the research of nanotubular structures based on 3d element oxides, in particular on the basis of vanadium oxide, which is indicated in [51]. The data of transmission electron microscopy (Belgium) are given in [52], which revealed the direction of whisker growth and optical microscopy (Japan) data on thin whiskers extracted from the chloride flux.

The results of theoretical and experimental studies of the formation of whiskers in the course of solid-phase reactions in reaction mixtures of refractory titanates of alkali and alkaline-earth metals, as well as oxides, are presented in [53]. It is established that solid-phase transformations initiated by border migration lie at the basis of whisker formation processes. In [54, 55], the problems of growing whiskers of inorganic compounds from solution-melts of various compounds are analyzed.

Thus, the above data underscore the fact that the problem is promising, interesting, causes deep discussions, disputes. Scientists do not hesitate to express their opinion and in some cases, a multi-polar one among themselves, which emphasizes once again the fact that this direction of science is rapidly developing.

5. Methods of research

The following methods are used during the research:

- statistical analysis (to determine the positive and negative aspects of the use of crystal growth mechanisms);
- analysis of research results (to determine the dynamics of the use of a particular mechanism for growing crystals);
- hypothetical-deductive method (when acquainting the actual research material in the field of growth of threadlike crystals, which additionally require in-depth analysis of information sources);
- method of generalizing the results (to establish the general properties and trends characteristic of the investigated crystal growth mechanisms).

6. Research results

If consider in general the typical process of crystal growth, then it is nothing more than a chemical reaction of the type:

1. The solid phase is a crystal.
2. The liquid phase is a crystal.
3. The gas is a crystal.

Undoubtedly, the most interesting are the processes of growing crystals from solutions or melts. If consider the

processes of growing crystals in solutions, then during the cooling of such solution, it is uniquely supersaturated and as a result, the excess material becomes a crystal. If the solvent itself evaporates, the solution is again supersaturated, and crystals are formed in the dissolved substance.

In the process of heating the crystals to the melting point, they melt, and the crystal lattice breaks down, and the crystals become an amorphous liquid. In the process of cooling at a temperature below the melting point, again a large number of crystals appear in the solidifying melt.

The growth of such crystals in the first stage is quite arbitrary, since the dimensions of the crystals are small, and they have the shape of a regular polyhedron. If two growing crystals meet each other, this means stopping their growth. After that they already have an irregular shape and form a polycrystal with a free orientation and a large number of crystalline grains.

Two types of crystallization are considered in papers [56, 57] – poly-component and one-component. If this is one-component crystallization, then we are dealing with only one component, a crystallizable crystal. If, in addition to the component that directly forms the crystal, there are other components, then this type is called poly-component.

If to talk about the mechanisms of crystal growth, then there are basically two of them in principle. In the first case, during the growth of the crystal, the growing surface moves due to the lateral displacement of the steps (a layered mechanism), in the second, a continuous movement along the normal to the surface occurs (a normal mechanism).

6.1. Layer-by-layer crystal growth. In this paper, the regularities of the mechanisms of crystal growth are examined using the example of the Kossel model.

The model is a plane-faced crystal in the form of cubes. The structure of the crystal is such that the neighboring cubes have common faces, and each lattice has six neighbors inside the lattice.

Fig. 1 shows the model of layer-by-layer crystal growth.

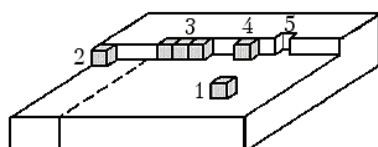

Fig. 1. Layer-by-layer crystal growth model

A single atom (cube) in this case to the crystal surface can join only one face (1). At the same time, it can tear itself away and will not hold firm. The growth of the layer is preceded by the formation of a monolayer, and it is to its edges that the atom will be joined by two faces (2). However, the process of layer growth begins actively in the case of the formation of a triangular corner, to which the cube is already joined by three faces (3). In the future, the mechanism will be repeated cyclically, the layers will be built, forming the crystal itself.

This construction mechanism helps to build the correct crystal structure, completely symmetrical. The face will be moved laterally by the lateral propagation of the steps and, therefore, such a crystal growth mechanism is called layered.

The growth of crystals can also be considered on a two-dimensional model (Fig. 2).

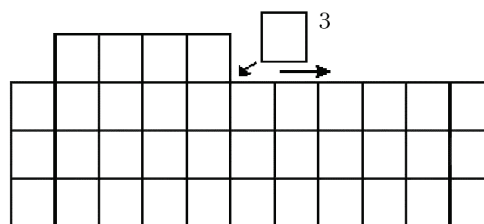

Fig. 2. Two-dimensional crystal growth model

In this model, the stage disappears and in order for the crystal to grow, step sources are needed, and a new step on the face may appear when a two-dimensional embryo appears.

In Fig. 2, it can be seen that a new layer may appear only after the formation of the previous layer has been completed. If this does not happen, a new layer will not appear.

The Kossel model is quite simple and shows only the modeling of the process, in fact, the growth of crystals is much more difficult. At the same time, it is necessary to take into account, at least, the inverse dissolution process, the violation of supersaturation or supercooling of solutions on the growing surface of the crystal, and many other factors. If this is not taken into account, the processes of normal growth of the crystal and its degree of perfection will be violated.

Investigations of crystal growth by this mechanism have shown that the energy of adsorption of intrinsic particles on the surface of the crystal itself is different. In a state of saturation at a certain temperature and concentration of matter in a medium, the number of ions that attach to the surface of the crystal per unit time and are separated from it are practically the same.

It is clear that near the top of the crystal and partly its edges, the adsorption energy is higher than on the smooth surface of the face, so it is here that the particles will stay longer and their density in these areas will be higher. Therefore, while maintaining a certain predetermined temperature, it is possible to increase the necessary supersaturation indices. And this will lead to the preservation of the required desorption rate.

In turn, these actions will lead to the fact that an increase in concentration will increase the flow of particles to the face, which will certainly lead to an increase in the number of adsorbed particles. And, as noted at the beginning of the article, for a further steady increase in the size of the islets (embryos) it is necessary that it (the embryo) reach a size that corresponds to the desired curvature of the end face of the layer. And, of course, the nucleation of such layer will occur precisely in the places of the greatest accumulation of particles, that is, near the top of the crystal (its edges).

Well and in the further the formed layer will extend on the verge, and on fractures of its end face particles will be adsorbed most strongly and for considerable time interval. At the time when the layer completely covers the entire face, the step will disappear and a certain time will be required until a new two-dimensional germ begins to combine, first of all, the thermal fluctuations and, subsequently, the concentration fluctuations. This embryo will provide the possibility of overlapping the face with a newly formed layer. The existence of two-dimensional

nuclei and the growth of a face by layers of matter were experimentally proved in the study of the dislocation-free faces of silver crystals, as indicated in [58].

However, it should be noted that if the layer grows, the face must be perfectly smooth, which corresponds to this crystal growth mechanism. However, on the faces of the crystal there is really no smooth surface, it can be sufficiently embossed with well-defined growth bumps. And the rate of growth of crystals is actually higher than the speed that is considered in the example of the model.

Fig. 3 shows various crystals that are grown by a layer-by-layer mechanism [58].

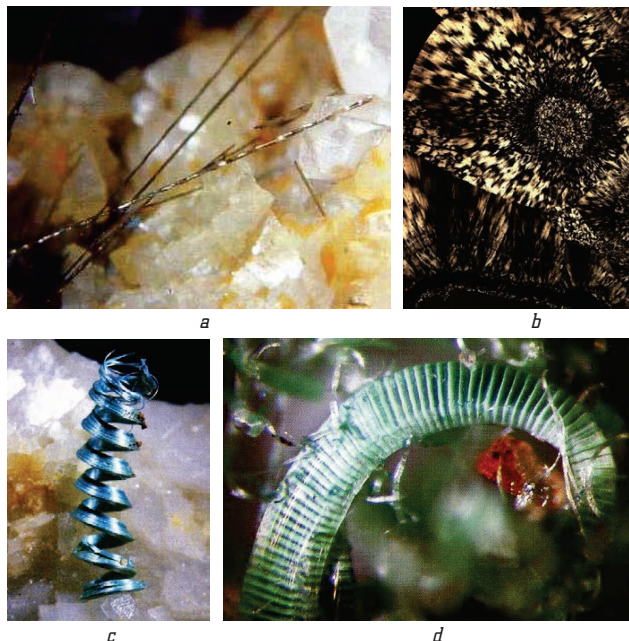

Fig. 3. Crystals grown by a layer-by-layer mechanism:
a – malachite crystal; *b* – chalcedony crystal; *c* – millerite crystal;
d – pyrite crystal

It shows the dislocation mechanism of crystal growth (a spiral version), which is characteristic for both natural and artificial crystals.

6.2. Normal crystal growth. The Kossel model allows to consider the processes of normal growth of crystals. Given the existence of short-range relationships (attraction between cubes having common faces), it should be recognized that atoms of other faces that do not have such attraction can't grow by a layer mechanism. After all, unambiguously, the attachment of atoms to such face occurs uniformly and then the growth will go all along the line along the normal to its surface. That's why such mechanism is called normal (Fig. 4).



Fig. 4. The process of normal crystal growth

The most stable form of crystals is equilibrium. The processes of this direction were carried out by the scientists – Curie, Kossel, Wulff and others. As a research

result, it is found that in ionic crystals the crystal growth form is similar to the equilibrium one. The vertices and edges of such crystals are not dulled by faces.

Fig. 5 shows examples of the equilibrium shape of some crystal compounds.

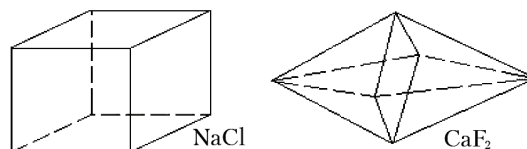

Fig. 5. The equilibrium shape of the crystals of certain compounds

Also, studies have shown that in nonpolar crystals, for example, with a metal bond, the growth form is not equilibrium. In this case, the particles in the vertex are connected with the crystal itself more weakly, and when detached from the crystal, they are detached from them, which leads to the appearance of new faces.

Fig. 6 shows an example of the equilibrium shape of a nonpolar crystal.

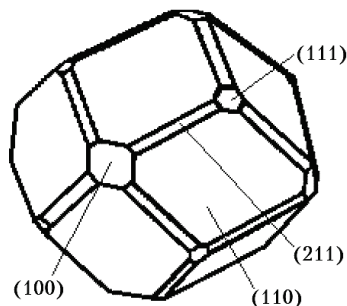

Fig. 6. An example of the equilibrium form of a nonpolar crystal

The carried out researches have shown that the perfect crystal, as well as the equilibrium form, can arise only at small supersaturations. And the problem of maintaining the homogeneity of the crystal increases in proportion to the growth of the crystal itself and an increase in the supersaturation degree.

The process of growing a crystal in a stationary state is considered. If gradually increase the intensity of the oxygen flow, then the layer of material that crystallizes will melt. The resulting melt will flow from the crystal head to its edge, and a roller will form on the lateral surface.

The position of the free surface of the liquid in the region adjacent to the edge of the crystal will be determined by the angle formed by the normals to the surface of the liquid and the crystal growth direction. With an increase in such angle, the energy losses will increase due to the radiation of the heat of the roller, which will lead to the crystallization of part of the melt. And this process will occur until an excessive amount of melt is formed under the influence of the flow of oxygen. In this case, the crystal will constantly grow with increasing oxygen intake.

Thus, the angle at the top of the growing crystal will be determined by the rate of increase in the flow of oxygen, as confirmed in [59].

Fig. 7 shows ice crystals that are formed just by the normal mechanism of crystal growth in windy weather and high speed of movement [58].



Fig. 7. Ice crystals obtained under conditions corresponding to the normal growth mechanism of crystals

Fig. 8 shows crystals grown by the normal mechanism of crystal growth [58].

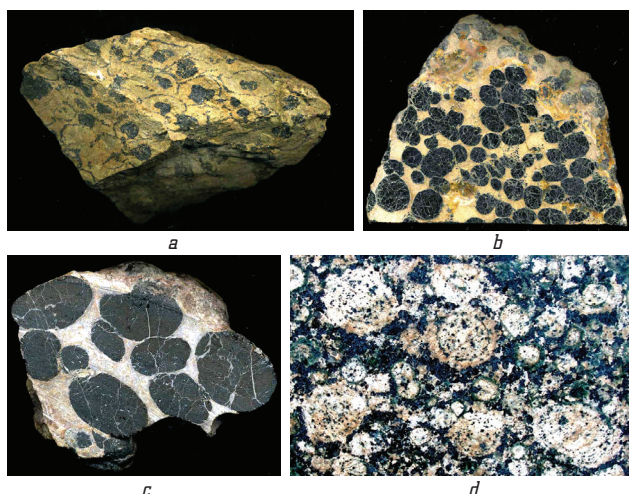

Fig. 8. Crystals grown by the normal mechanism of crystal growth:
a – olivine; *b, c* – chrome-spinels; *d* – ovoid of K-Na feldspar

The process of growing a crystal, therefore, depends essentially on the thermal conditions in the roller vicinity. These conditions should ensure the flow of the melt, its accumulation and the immediate crystallization of the material. In turn, crystallization is impossible without a selected temperature gradient along the crystal gradient itself.

If consider the factors that affect the thermal conditions in the growth of crystals, then should pay attention to the flame shape, the thermal characteristics of the crystallization chamber itself, the burner design, and also the material and construction of the chamber itself.

The carried out researches have shown that infringement of the given conditions will lead to melting of a crystal in those places where these conditions have been broken.

The review and analysis of the research results shows that whiskers have a sufficiently high melting point and strength, they have a high modulus of elasticity. Many threadlike crystals are inert to various materials, including – metal, polymer and even ceramic, and to very high temperatures. Unlike polycrystalline fibers, whiskers are not subject to recrystallization processes. Namely, such processes can cause a sharp drop in strength at high temperatures.

The review shows that whiskers have unique electrical and optical characteristics. That is why thin films of such crystals are widely used in transparent conducting electrodes and solar batteries, and the doping processes allow obtaining materials that have good sensory characteristics.

The conducted experiments shows that whiskers of refractory metals and compounds are obtained, as a rule, by the method of deposition from the gas phase in high-temperature furnaces of different action – from periodic to continuous. In this case, the conductivity of the crystal can be detected by an external device, since antibodies are attached to the crystal, which interact with the «hostile» molecule, which in turn is large and carries a charge. Thus, by attaching to the nanocrystal through the antibody, it causes a change in the conductivity of the crystal.

7. SWOT analysis of research results

Strengths. When layer-by-layer mechanism of crystal growth is used, the strengths of the process are:

1. When this crystal growth mechanism is used, crystals of a regular symmetrical structure are obtained.
2. The process of crystal growth is fairly consistent, a new layer can appear only after the formation of the previous one has been completed.

With a normal crystal growth mechanism, the strengths are:

3. The surfaces of any orientation of the crystal, including the irrational ones, move parallel to itself, as a result of which we have rounded crystal surfaces that have grown from the melt.
4. With the growth of crystals from the melt under conditions of high temperature gradients and with the motion of the melt, the normal growth of the crystal is usual and not complicated enough.

5. The normal mechanism of crystal growth effectively works exclusively in a mobile environment. The curvature of the crystal surface in this case generally corresponds to the curvature of the isothermal surface.

6. The normal crystal growth mechanism is effective when there are non-singular surfaces with a large number of attachment sites. Particles can thus be attached almost anywhere, which causes the parallel movement of the surface of the growing crystal.

Weaknesses. The disadvantages of carrying out the processes of growing crystals by a layered mechanism include:

1. This growth mechanism is realized only in the presence of steps on the surface of the substrate, the source of which, in particular, is the natural roughness of faces with large Miller indices.
2. At a low temperature close to $T=0$ K, the step front is atomically smooth. In this case, the thermal fluctuations that appear at finite temperatures lead to the appearance of kinks in the steps.
3. The process of formation of two-dimensional «embryos» is sufficiently sensitive to supersaturation, and the

probability of its occurrence at rates below 45–50 % is sufficiently small.

The disadvantages of carrying out the processes of growing crystals by a normal mechanism include:

1. The mechanism is not effective for a smooth crystal surface.

2. The need to take into account a number of factors directly affecting the processes of crystal growth and the degree of its perfection (dissolution, supersaturation, cooling of the solution, etc.).

3. It is necessary to observe the condition that there must be enough «favorable» places on the surface for fixing the atoms, which is not always feasible.

Opportunities. Investigations of crystal growth mechanisms have shown that they are sufficiently effective in terms of obtaining the necessary configuration and modification of the crystals themselves. With a controlled and accurate observance of the parameters of the carried out processes, it is possible to preserve the desired properties and indices of the resulting crystal.

Threats. A problematic issue in growing crystals with these mechanisms from the melt is the preservation of the purity of the metal itself, especially if it is in the container in the molten state for a long time [60]. The crystal must be further machined, as a result of which it deforms and loses its shape. That's why it needs to be recrystallized. However, the process of recrystallization is rather complicated, if it is carried out with disturbances, this will lead to a change in the number, shape, size, perfection and orientation of the crystals themselves [61].

8. Conclusions

1. The layer-by-layer mechanism of crystal growth is investigated. Studies have shown that when realizing the growth of crystals using this mechanism, one should pay the most serious attention to the formation of two-dimensional nuclei and the supersaturation of solutions.

2. Investigations of crystal growth by the «normal» mechanism show that when using such growth mechanism, it is necessary to strictly observe the condition that:

- on the surface there should be quite a lot of «energetically favorable» places of fixation of atoms;
- the state of the surface here is the decisive factor in the process.

References

1. Gow K. V., Chalmers B. The preparation of high melting point metal single crystals and bicrystals with pre-determined crystallographic orientation // *British Journal of Applied Physics*. 1951. Vol. 2, No. 10. P. 300–303. doi: <http://dx.doi.org/10.1088/0508-3443/2/10/305>
2. Hurle D. T. J. Temperature oscillations in molten metals and their relationship to growth striae in melt-grown crystals // *Philosophical Magazine*. 1966. Vol. 13, No. 122. P. 305–310. doi: <http://dx.doi.org/10.1080/14786436608212608>
3. Utech H. P., Flemings M. C. Elimination of Solute Banding in Indium Antimonide Crystals by Growth in a Magnetic Field // *Journal of Applied Physics*. 1966. Vol. 37, No. 5. P. 2021–2024. doi: <http://dx.doi.org/10.1063/1.1708664>
4. Nacken R., Neues J. B. Über das Wachstum von Kristallpolyedern in ihrem Schmelzfluß // *Mineralog. Geol. Palaontol. Ref. Teil*. 1915. No. 2. P. 133–164.
5. Kyropoulos S. Ein Verfahren zur Herstellung großer Kristalle // *Zeitschrift Für Anorganische Und Allgemeine Chemie*. 1926. Vol. 154, No. 1. P. 308–313. doi: <http://dx.doi.org/10.1002/zaac.19261540129>

6. Czochralski J. Ein neues Verfahren zur Messung des Kristallisationsgeschwindigkeit der Metalle // *Zeitschrift für Physikalische Chemie*. 1918. No. 92. P. 219.
7. Sworn C. H., Brown T. E. The growth of dislocation-free copper crystals // *Journal of Crystal Growth*. 1972. Vol. 15, No. 3. P. 195–203. doi: [http://dx.doi.org/10.1016/0022-0248\(72\)90119-4](http://dx.doi.org/10.1016/0022-0248(72)90119-4)
8. Howe S., Elbaum C. The occurrence of dislocations in crystals grown from the melt // *Philosophical Magazine*. 1961. Vol. 6, No. 70. P. 1227–1240. doi: <http://dx.doi.org/10.1080/14786436108243373>
9. Hukin D. A. Improvements in or relating to crucibles. Publ. 04 June 1972. URL: <https://patents.google.com/patent/GB1269762A/en?q=GB1269762A>
10. Carlson O. N., Schmidt F. A., Peterson D. T. Electrotransport of interstitial atoms in yttrium // *Journal of the Less Common Metals*. 1966. Vol. 10, No. 1. P. 1–11. doi: [http://dx.doi.org/10.1016/0022-5088\(66\)90038-5](http://dx.doi.org/10.1016/0022-5088(66)90038-5)
11. Schmidt F. A., Warner J. C. Electrotransport of carbon, nitrogen and oxygen in vanadium // *Journal of the Less Common Metals*. 1967. Vol. 13, No. 5. P. 493–500. doi: [http://dx.doi.org/10.1016/0022-5088\(67\)90084-7](http://dx.doi.org/10.1016/0022-5088(67)90084-7)
12. Peterson D. T., Schmidt F. A. Electrotransport of carbon, nitrogen and oxygen in lutetium // *Journal of the Less Common Metals*. 1969. Vol. 18, No. 2. P. 111–116. doi: [http://dx.doi.org/10.1016/0022-5088\(69\)90129-5](http://dx.doi.org/10.1016/0022-5088(69)90129-5)
13. Peterson D. T., Schmidt F. A. Preparation of high purity thorium and thorium single crystals // *Journal of the Less Common Metals*. 1971. Vol. 24, No. 2. P. 223–228. doi: [http://dx.doi.org/10.1016/0022-5088\(71\)90099-3](http://dx.doi.org/10.1016/0022-5088(71)90099-3)
14. Bradley A. J. CX. The allotropy of manganese // *The London, Edinburgh, and Dublin Philosophical Magazine and Journal of Science*. 1925. Vol. 50, No. 299. P. 1018–1030. doi: <http://dx.doi.org/10.1080/14786442508628546>
15. Mills D., Craig G. Etching dislocations in zirconium // *Journal of Electrochemical Technology*. 1966. Vol. 4. P. 300.
16. Field W. G., Wagner R. W. Thermal imaging for single crystal growth and its application to ruby // *Journal of Crystal Growth*. 1968. Vol. 3–4. P. 799–803. doi: [http://dx.doi.org/10.1016/0022-0248\(68\)90270-4](http://dx.doi.org/10.1016/0022-0248(68)90270-4)
17. Drabble J. R. The arc transfer process of crystal growth // *Journal of Crystal Growth*. 1968. Vol. 3–4. P. 804–807. doi: [http://dx.doi.org/10.1016/0022-0248\(68\)90271-6](http://dx.doi.org/10.1016/0022-0248(68)90271-6)
18. Gasson D. B., Cockayne B. Oxide crystal growth using gas lasers // *Journal of Materials Science*. 1970. Vol. 5, No. 2. P. 100–104. doi: <http://dx.doi.org/10.1007/bf00554627>
19. Precht W., Hollox G. E. A floating zone technique for the growth of carbide single crystals // *Journal of Crystal Growth*. 1968. Vol. 3–4. P. 818–823. doi: [http://dx.doi.org/10.1016/0022-0248\(68\)90274-1](http://dx.doi.org/10.1016/0022-0248(68)90274-1)
20. Siegel R. W., Hahn H. Nanophase materials // *Current Trends in Physics of materials*. Singapore: World Sci. Publ. Co, 1987. P. 403–420.
21. Siegel R. W. What do we really know about the atomic-scale structures of nanophase materials? // *Journal of Physics and Chemistry of Solids*. 1994. Vol. 55, No. 10. P. 1097–1106. doi: [http://dx.doi.org/10.1016/0022-3697\(94\)90127-9](http://dx.doi.org/10.1016/0022-3697(94)90127-9)
22. Nitevidnye kristally // *Nitevidnye kristally i tonkie plenki: proceedings. Voronezh: VPI*, 1975. 466 p.
23. Nitevidnye kristally dlya novoy tekhniki: proceedings. Voronezh: VPI, 1979. 231 p.
24. Part 1. Nitevidnye kristally // *Nitevidnye kristally i neferromagnitnye plenki: proceedings. Voronezh: VPI*, 1970. 287 p.
25. Part 2. Tonkie plenki // *Nitevidnye kristally i neferromagnitnye plenki: proceedings. Voronezh: VPI*, 1970. 300 p.
26. Artemev S. R. Present concepts of non-traditional methods of growing of metal whisker crystals. Pulling of whiskers from solution // *Technology Audit and Production Reserves*. 2015. Vol. 3, No. 4 (23). P. 8–12. doi: <http://dx.doi.org/10.15587/2312-8372.2015.42409>
27. Artemev S. R. Current concepts of non-traditional methods of cultivation metal whisker crystals. Pulling whisker pole from melt // *Technology Audit and Production Reserves*. 2015. Vol. 2, No. 4 (22). P. 16–19. doi: <http://dx.doi.org/10.15587/2312-8372.2015.40499>
28. Artemev S. R. Study of whiskers' mechanical properties. creep and internal friction // *Technology Audit and Production Reserves*. 2014. Vol. 5, No. 3 (19). P. 16–18. doi: <http://dx.doi.org/10.15587/2312-8372.2014.27909>

29. Artemev S. R. Analysis of existent concepts of traditional methods of metal whiskers growing. Deposition of substance from the gas phase // *Technology Audit and Production Reserves*. 2016. Vol. 3, No. 3 (29). P. 34–37. doi: <http://dx.doi.org/10.15587/2312-8372.2016.70512>
30. Artemev S. R. Properties of whiskers. mechanical strength test // *Technology Audit and Production Reserves*. 2013. Vol. 6, No. 1 (14). P. 4–7. doi: <http://dx.doi.org/10.15587/2312-8372.2013.19533>
31. Artemev S. R., Andronov V. A., Semkiv O. M. Mechanical properties of whiskers // *Technology Audit and Production Reserves*. 2013. Vol. 5, No. 1 (13). P. 42–44. doi: <http://dx.doi.org/10.15587/2312-8372.2013.18393>
32. Artemev S. R., Shapov V. P., Tsymbal B. M. Investigation of methods of obtaining whiskers in composite material // *Technology Audit and Production Reserves*. 2018. Vol. 1, No. 3 (39). P. 8–14. doi: <http://dx.doi.org/10.15587/2312-8372.2018.124287>
33. Artemev S. R., Belan S. V. Properties and basic methods of receipt of threadlike crystals // *Eastern-European Journal of Enterprise Technologies*. 2013. Vol. 5, No. 1 (65). P. 22–26. URL: <http://journals.urau.ua/eejet/article/view/18160>
34. Existing notions of conventional breeding metal whiskers, their analysis / Artemev S. R. et al. // *Eastern-European Journal of Enterprise Technologies*. 2015. Vol. 1, No. 1 (73). P. 17–23. doi: <http://doi.org/10.15587/1729-4061.2015.36435>
35. Nomeri M. A. Kh. Poluchenie i issledovanie opticheskikh svoystv poluprovodnikovykh oksidov ZnO₂ i Zn₂O₃: PhD thesis. Voronezh, 2011. 128 p.
36. Tamman G. Die Aggregatzustande. Leipzig, 1922. 294 p.
37. Turnbull D., Fisher J. C. Rate of Nucleation in Condensed Systems // *The Journal of Chemical Physics*. 1949. Vol. 17, No. 1. P. 71–73. doi: <http://doi.org/10.1063/1.1747055>
38. Honigmann B. Gleichgewichts und Wachstumsformen von Kristallen. Dresden, 1958. doi: <http://doi.org/10.1007/978-3-642-45791-3>
39. Reynolds D. S. The art and Science of Growing Crystals / ed. by Gillman J. J. New York: Wiley, 1963. 493 p.
40. Ewald A. W., Tuft O. N. Gray Tin Single Crystals // *Journal of Applied Physics*. 1958. Vol. 29, No. 7. P. 1007–1009. doi: <http://doi.org/10.1063/1.1723351>
41. Weinstein M., Mlavsky A. I. Growth of GaP Crystals and *p-n* Junctions by a Traveling Solvent Method // *Journal of Applied Physics*. 1964. Vol. 35, No. 6. P. 1892–1894. doi: <http://doi.org/10.1063/1.1713764>
42. Wolff G. A., LaBelle H. E., Das B. N. Solution growth of (Zn, Hg) Te and Ga (P, As) crystals // *Transactions of the Metallurgical Society of AIME*. 1968. Vol. 242. P. 436–441.
43. Griffiths L. B., Mlavsky A. I. Growth of α -SiC Single Crystals from Chromium Solution // *Journal of The Electrochemical Society*. 1964. Vol. 111, No. 7. P. 805. doi: <http://doi.org/10.1149/1.2426257>
44. The diffusion mechanism in the formation of GaAs and AlGaAs nanowhiskers during the process of molecular-beam epitaxy / Cirlin G. E. et al. // *Semiconductors*. 2005. Vol. 39, No. 5. 557–564. doi: <https://doi.org/10.1134/1.1923565>
45. Dubrovskii V. G., Sibirev N. V., Cirlin G. E. Kinetic model of the growth of nanodimensional whiskers by the vapor-liquid-crystal mechanism // *Technical Physics Letters*. 2004. Vol. 30, No. 8. P. 682–686. doi: <https://doi.org/10.1134/1.1792313>
46. Dubrovskii V. G., Sibirev N. V. Growth rate of a crystal facet of arbitrary size and growth kinetics of vertical nanowires // *Physical Review E*. 2004. Vol. 70, No. 3. doi: <http://doi.org/10.1103/physreve.70.031604>
47. Properties of GaAs nanowhiskers grown on a GaAs(111)B surface using a combined technique / Tonkikh A. A. et al. // *Semiconductors*. 2004. Vol. 38, No. 10. P. 1217–1220. doi: <https://doi.org/10.1134/1.1808832>
48. Silicon nanowhiskers grown on (111) Si substrates by molecular-beam epitaxy / Schubert L. et al. // *Applied Physics Letters*. 2004. Vol. 84, No. 24. P. 4968–4970. doi: <http://doi.org/10.1063/1.1762701>
49. Structural and microstructural features of functional materials based on cuprates and manganites / Tretyakov Y. D. et al. // *Russian Chemical Reviews*. 2004. Vol. 73, No. 9. P. 881–898. doi: <https://doi.org/10.1070/rc2004v073n09abeh000920>
50. Crystallization of amino acids on substrates with superficial chiral reliefs / Grigorieva A. V. et al. // *Mendelevov Communications*. 2004. Vol. 14, No. 4. P. 150–152. doi: <http://doi.org/10.1070/mc2004v014n04abeh001961>
51. Vliyanie predystorii polucheniya na uporyadochenie strukturnykh elementov kserogeley pentoksida vanadiya / Peryshkov D. V. et al. // *DAN Khimiya*. 2006. Vol. 406, No. 2. P. 203–208.
52. A simple method of growth and lithiation of Ba₆Mn₂₄O₄₈ whiskers / Goodilin E. A. et al. // *Journal of Materials Chemistry*. 2005. Vol. 15, No. 16. P. 1614. doi: <http://doi.org/10.1039/b416512h>
53. Shapov V. P., Sebko V. V., Shestopalov A. V. Tekhnologicheskie zakonomernosti protsessov, kotorye lezhat v osnove massovogo proizvodstva viskerov neorganicheskikh tugoplavkikh soedineniy // *Vestnik NTU «KhPI»*. Seriya: khimiya, khimicheskaya tekhnologiya i ekologiya. 2014. Vol. 27. P. 114–142.
54. Shapov V. P., Pitak I. V., Shestopalov A. V. Tekhnologicheskie zakonomernosti protsessov obrazovaniya i rosta nitevidnykh kristallov neorganicheskikh soedineniy iz rastvor-raspлавov // *Vestnik Kremenchugskogo natsional'nogo universiteta imeni M. Ostrogradskogo*. 2014. Vol. 3. P. 25–29.
55. Shapov V. P., Pitak I. V., Shestopalov A. V. K voprosu ob organizatsii potochnoho proizvodstva nitevidnykh kristallov tugoplavkikh neorganicheskikh soedineniy metodom kristalizatsii iz rastvor-raspлавov na osnove galoidov shhelochnykh metallor // *Zhurnal integrirovannykh tekhnologiy i energoberezheniya*. 2015. No. 1. P. 47–60. URL: http://repository.kpi.kharkov.ua/bitstream/KhPI-Press/28545/1/ITE_2015_1_Shapov_V_K_voprosu.pdf
56. Givargizov E. I. Rost nitevidnykh i plastinchatykh kristallov iz para. Moscow: Gosizdat, 1976. 192 p.
57. Givargizov E. I. Teoriya rosta i metody vyrashhivaniya kristallov. Moscow: Mir, 1981. 220 p.
58. Spiridonov E. M. Geneticheskaya mineralogiya. Ontogeniya. Rost kristallov. MGU im. M. Lomonosova. NII Mekhaniki, 1995. 166 p.
59. Falckenberg R. Growth of Mg-Al spinel crystals of large diameter using a modified flame fusion technique // *Journal of Crystal Growth*. 1975. Vol. 29, No. 2. P. 195–202. doi: [http://doi.org/10.1016/0022-0248\(75\)90224-9](http://doi.org/10.1016/0022-0248(75)90224-9)
60. Nigh H. E. A Method for Growing Rare-Earth Single Crystals // *Journal of Applied Physics*. 1963. Vol. 34, No. 11. P. 3323–3324. doi: <http://doi.org/10.1063/1.1729186>
61. Burgers W. C. The art and Sciens of Growing Crystals. New York, 1963. 416 p.

Artemev Sergey, PhD, Associate Professor, Head of the Department of Occupational Safety and Technogenic and Ecological Security, National University of Civil Defense of Ukraine, Kharkiv, Ukraine, e-mail: arctic2667@gmail.com, ORCID: <http://orcid.org/0000-0002-9086-2856>